

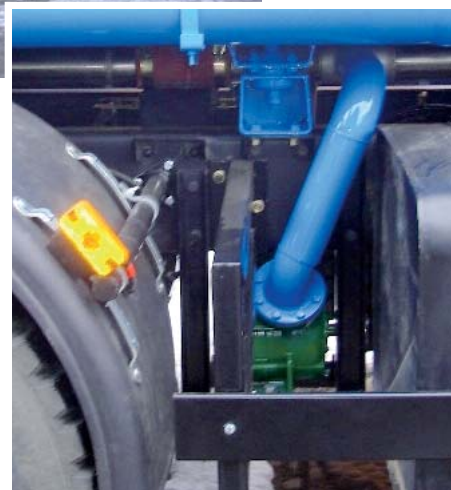

**DICKOW  
PUMPEN**

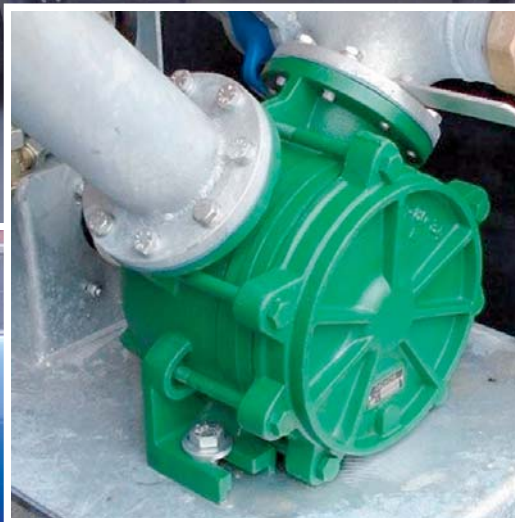

**Self Priming  
Side Channel Pump  
Tank Truck Execution**

**Type WPC 831 T**

## Field of application

The Dickow pump type WPC 831 T was developed especially for the use in tank trucks. The compact and space saving design is tailored for the little room available. A mounting flange for the direct connection of a hydraulic motor is standard.

The pumps can handle clean liquids without solids, like e.g. all kinds of fuels and water. Since side channel pumps are self-priming, they can also handle a mixture of liquid with gas respectively air. This is important at low filling levels of the tank in order to reach the maximum possible unloading volume.

## Design

The WPC 831 T is a one stage centrifugal pump with a ring channel on one side. The shape of this channel allows to reach high heads and self-priming ability. The star shaped side channel impellers are mounted to the shaft in axial floating position. A key transmits power from the shaft to the impeller. Generously dimensioned, grease lubricated ball bearings hold shaft in place. Shaft is sealed by a single mechanical seal. The side channel working principle requires tight clearances between the rotating impeller and the casing. During operation with properly filled pump, a stable fluid film between the impeller and casing will center the impeller in the casing and avoid metallic contact and seizing of the impeller.

**Materials:** standard execution  
(stainless steel execution)

Casing parts: Cast iron (1.4408)

Impeller: G-SnBz (1.4457)

Shaft: 1.4021 (1.4571)

## Relief valve

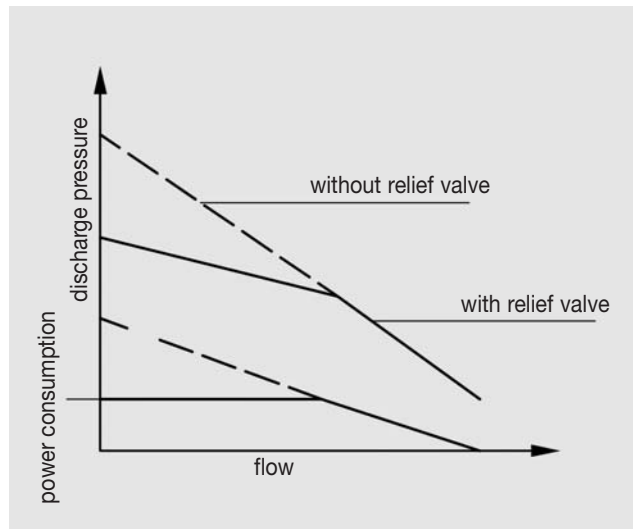

Contrary to centrifugal pumps, the side channel pumps generate a steep head rise and an increased power consumption at lower flow rates. Power consumption and discharge pressure reach the maximum at closed discharge valve. To protect discharge pipes and to avoid overload of the motors, additional relief valves can be fitted to the WPC-pumps.

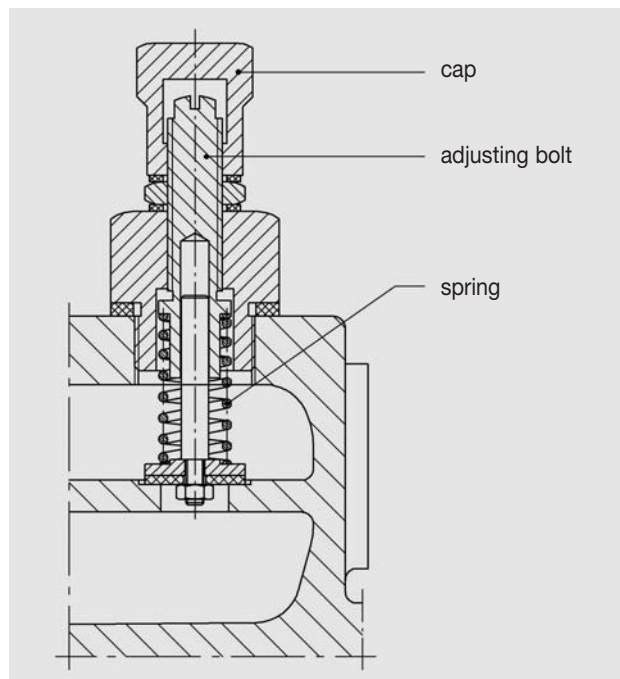

**Sectional drawing**

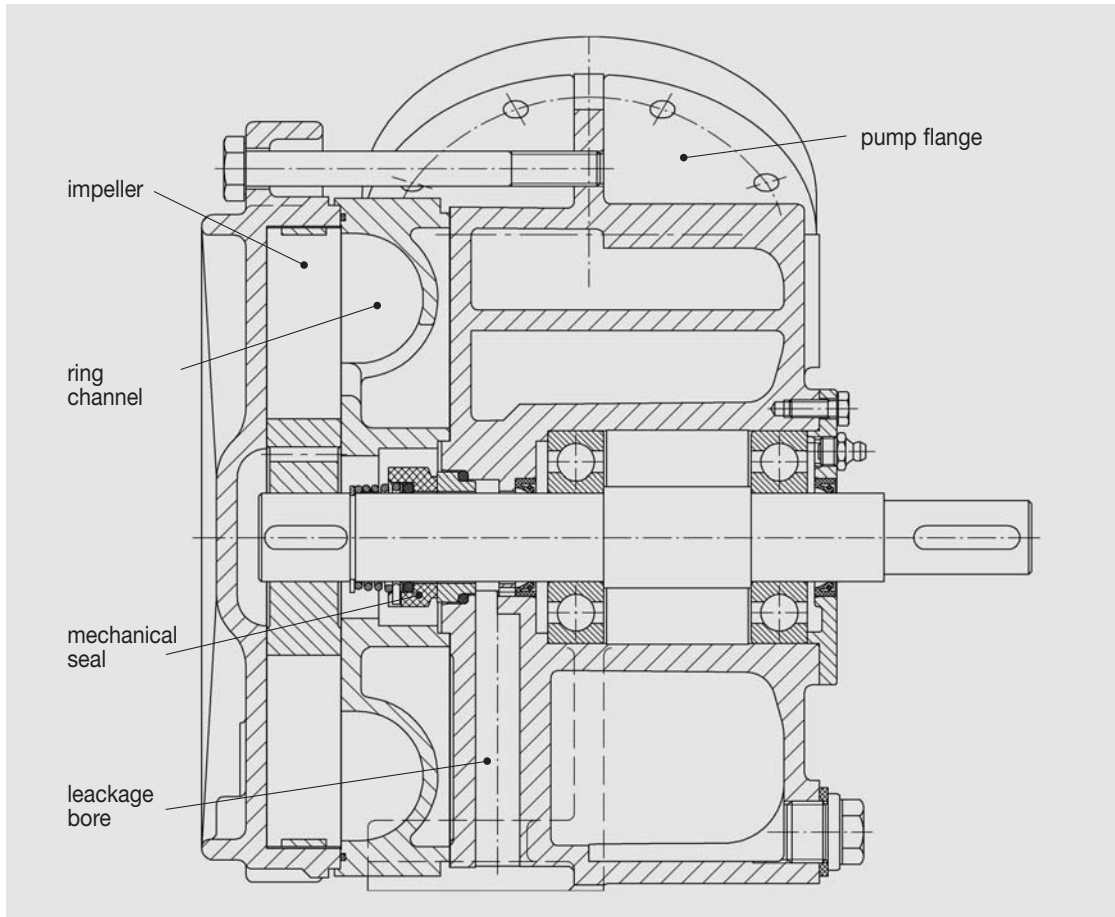

**Dimensional drawing**

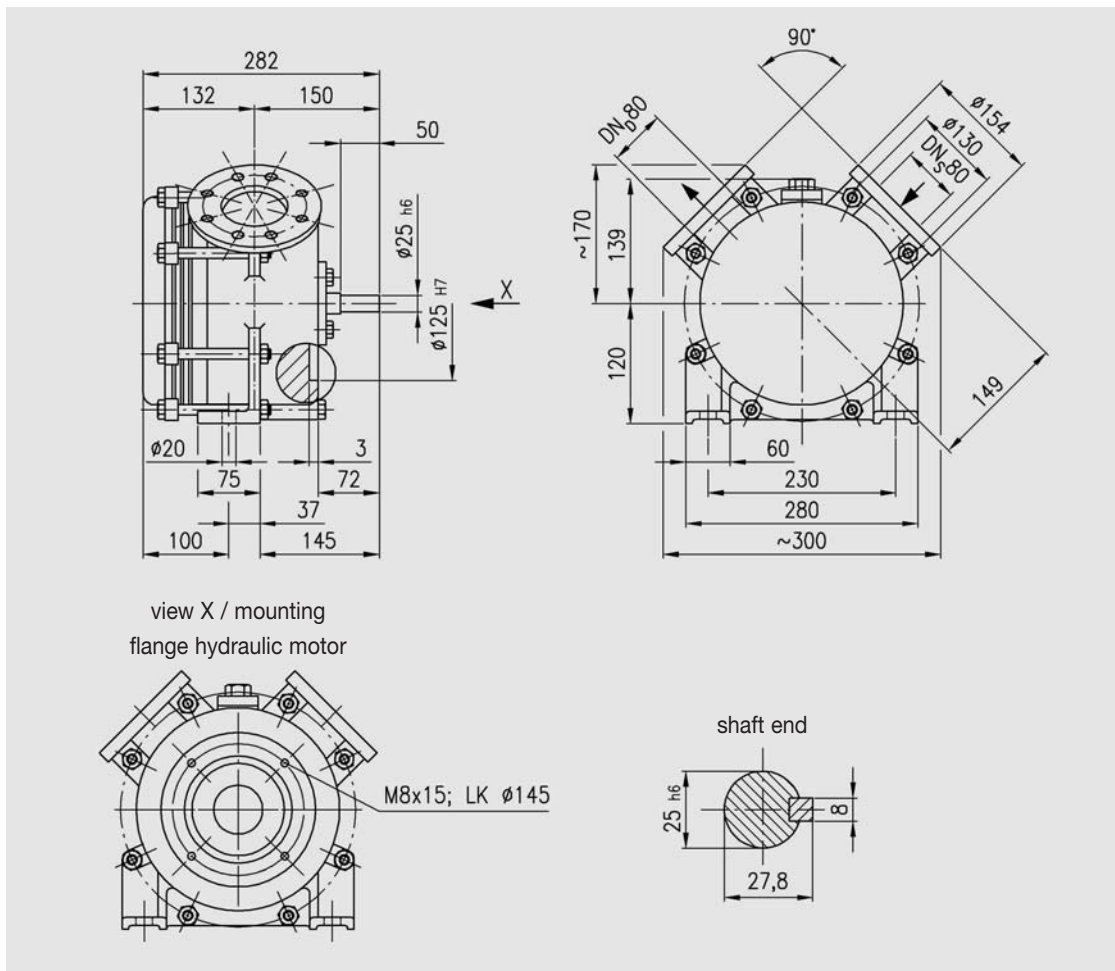

# Performance range

